

# PRODUCT CATALOGUE



CUSTOMISED MATERIAL HANDLING SOLUTIONS  
TRANSFER CARS  
COIL & PIPE STORAGE SYSTEMS  
AUTOMATION  
PICK & PLACE  
RECONDITIONING



**ARMATIC**®  
ENGINEERING PRIVATE LIMITED



#8, 27th Cross, Banashankari 2nd Stage, Bangalore-560 070, India  
Tel:+91-80-2671 7078, 2671 1733, Fax: +91-80-2671 3138  
Email: mail@armaticengineering.com, Website : www.armaticengineering.com

MOVING & LIFTING INDUSTRIES SINCE 1968

WE BELIEVE

IF YOU CAN MAKE IT, WE CAN HANDLE IT.





- ▲ As an ISO certified material handling equipment manufacturer, Armatic Engineering Private Limited has a lineup of approximately 150 custom built products, the largest in India, that allows us to meet the needs of the manufacturing industry in every field.
- ▲ During our history of more than 50 years since our company was founded in 1968, Armatic Engineering Private Limited has built its reputation and success by critically examining customer needs, developing dependable technologies, wide-ranging innovation in design, maintaining a reasonable cost structure and successfully keeping up to our commitments. The fundamental business philosophy of our company is gratitude and in order to give shape to this philosophy, we will continue to produce dependable products for our customers as we look forward to the next 100 years.
- ▲ Our range of products include Coil Handling Equipment, Transfer Cars, Slab Tongs, Billet Tongs, Ingot Tongs, Bloom Tongs, Up - Down Enders (Tilters), Rotators, Electro - Hydraulic Cactus & Rope Grabs, Sheet Pack Lifters, Sheet Plate Lifters, Spreader Beams, Truck Mounted Hydraulic Cranes, among others. We have designed equipment up to SWL 200 Tons and built upto SWL 185 Tons.
- ▲ We have exported our products to Australia, Bangladesh, Columbia, Dubai, Egypt, Ethiopia, Georgia, Indonesia, Italy, Kenya, Malaysia, Mexico, Nepal, Nigeria, Oman, Pakistan, Rwanda, Saudi Arabia, Turkey, Vietnam.



## MANUFACTURING

- C-hooks – with rotation, container loading etc.
- Vertical Coil Tongs – single and double rim
- Coil Lifters – rack and pinion & parallelogram
- Convector Plate Lifters
- Transfer Cars – electrical and battery operated
- Slab, Ingot, Billet, Bloom Tongs
- Up-Down Enders (Tilters) – mechanical & electro - hydraulic
- Electro-Hydraulic Cactus and rope Grabs
- Sheet Pack & Plate Lifters
- Spreader Beams
- Truck mounted hydraulic cranes
- Stack Turnover device - Hydraulic
- Roll Lifting Tong

## SEGMENTS

- Flat products
- Long Products
- Coils
- Ingots / Billets
- Scrap
- Steel, Copper, Aluminum, Stainless steel
- Wire Rod

### TEAMWORK AS AN ARTFORM.

We have an experienced and passionate group of designers, developers and project managers. Every client we work with becomes a part of the team. Together we face the challenges and design the ultimate product.

### TRANSPARENT COMMUNICATION

We keep the lines of communication wide open and reciprocal. You will be informed and empowered from inception to project review and beyond. We think that's key to a happy, productive relationship and to the best results.

### A THRIVING PARTNER ECOSYSTEM. BUILT TO EXPAND

Every project has its own unique goals and vision. Whatever your project demands, our extended network of strategists, creatives and technology specialists is always eager to pitch in.

**One team, many talents.**

### INSTALLATION & COMMISSIONING

No one understands our products quite like our dedicated personnel. Whatever the product, location or application, Armatic's experienced and highly-trained specialists will handle the installation with professionalism, adeptness and in accordance with local safety requirements.

### BENEFITS

Eliminate the challenge of coordinating multiple on-site teams when installing new equipment. Armatic project managers can handle the installation and commissioning of equipment from start to finish. From the early project planning stage, coordinating needed tools and manpower, executing the project on-site to conducting follow up meetings with your staff, our team manages each step of the process to ensure that installations are on time and under budget. Project meetings throughout the process guarantee that everyone is on the same page in terms of safety, costs and installation times.

All newly installed equipment is run through rigorous on-site testing to ensure that system equipment hardware and software is working as it should. Predetermined operation sequences are tested and all on-site adjustments are configured to ensure your equipment is ready for your most demanding applications.

Once equipment is installed and running, we remain available for you.

### CONSULTANCY

We combine the best of design thinking, user research, strategy, and cutting-edge technology to deliver innovative solutions for better results.

With extensive experience across industries, technologies, and regions, we bring a fresh perspective to your biggest challenges. Our design process, advanced software practices and digital thought leadership have been honed after 50 years. The end result? Sophisticated execution and an eye toward perfection.

Powered by our design-led innovation process we deliver end-to-end experiences to help businesses grow.

### RECONDITIONING & REFURBISHING

We offer complete factory reconditioning services. The factory-trained experts at our facility follow strict ISO guidelines and use genuine parts to deliver fully-inspected, like-new equipment.

Our technicians conduct an extensive reconditioning process:

- Units are completely torn down and inspected.
- Major sub-assemblies are verified for structural integrity.
- Report is sent to customer for parts to be reconditioned.
- Our trained personnel perform the necessary tasks.



45MT C-hook



13MT Container Loading C-hook



35MT C-hook with Built In Stand



15MT C-hook with rotation



20MT C-hook for Turnstile



0.5MT C-hook for Slits



30MT Coil Lifter

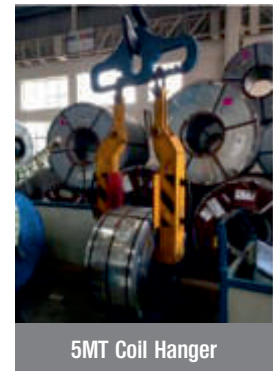

5MT Coil Hanger



20MT Parallelogram Coil Lifter

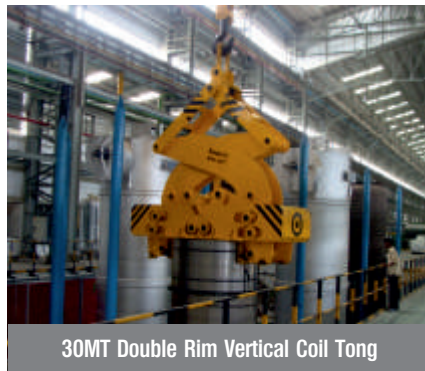

30MT Double Rim Vertical Coil Tong

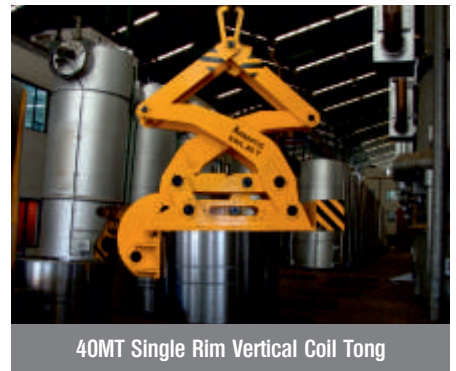

40MT Single Rim Vertical Coil Tong

## Coil Handling Equipment

When it comes to design, quality and purpose, we provide the utmost attention. Every coil handling equipment manufactured and supplied have been of the highest quality with impeccable attention to detail. We have always maintained 100% customer satisfaction to be our soaring priority.

### C - Hooks

To lift coils having bore horizontal, self-balanced, easy to operate, purely mechanical, pads made of steel / aluminum / PU, made for Hot & Cold coils, turnstile application, normal / slit coils, supplied with separate / built in parking stand.

**Number of Units Manufactured: 1300+ | Lifting Capacity: 0.5 MT - 45 MT | SWL - 1.25 | FoS: 3**

### Vertical coil tong

To lift coil with bore eye to sky, self balanced, automatic lock, positive gripping, Made for hot & cold

**Number of Units Manufactured: 200+ | Lifting Capacity: 5 MT - 45 MT | SWL - 1.25 | FoS: 3**

### Coil Lifters / Telescopic tongs/ Parallelogram tongs

Electrical / Hydraulic operated, rack and pinion type, reduces aisle space between coils while storage, 300° slewing, cable reeling drum, remote option available, all safety features built in like sensors, limit switches. Contact surface PU / steel / aluminum, foldable pads available, additional hooking arrangement can be provided. Made for hot & cold coils, cable reels & large pipes.

**Number of Units Manufactured: 100+ | Lifting Capacity: 5 MT - 45 MT | SWL - 1.25 | FoS: 3**

# TRANSFER CARS



70MT Transfer Car with Cable Reeling Drum



5MT Battery Operated Tube Transfer Car



40MT Battery Operated Transfer Car



80MT Flat Bed Transfer Car



10MT Transfer Car with Hydraulic Scissor Lift



35MT Transfer Car with Bottom Opening For Coil Car Access



130MT Flat Bed Transfer Car with Underground Bus Bar



20MT Mould Transfer car

Transfer of materials from one place to another. Available in electrical with cable reeling drum or cable drag chain, Battery operated with built in battery, battery charger and controller, with operator cabin, removable attachments on top bed, low bed, variable speed, continuous duty.

**Number of Units Manufactured: 200+ | Lifting Capacity: 5 MT - 130 MT | SWL - 1.25 | FoS: 3**

# SLAB TONGS, PLATE & SHEET LIFTERS



50MT Hot Slab Tong

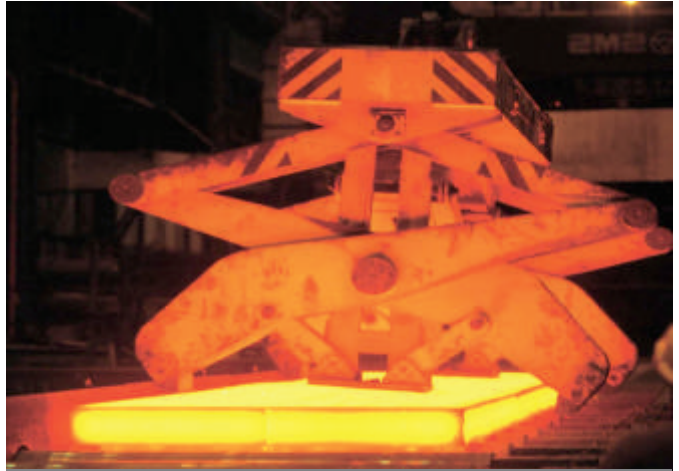

1200°C 25MT Hot Slab Tong



5MT Sheet Pack Lifter



25MT Stainless Steel Hot Plate Stack Lifter with Trolley



15MT Sheet Pack Lifter



5MT Aluminium Slab Tong

Mechanical / Electrical tongs for cold and hot materials, automatic lock, robust gripping pads, continuous duty.

Number of Units Manufactured: 130+ | Lifting Capacity: 5 MT - 50 MT | SWL - 1.25 | FoS: 3

# SPECIAL LIFTING EQUIPMENT



15MT Ingot Tong



18MT Aluminium Ingot Tong



1000°C Graphite Electrode Tong



Triple Rail Clamp



4T Convector/Inner Hood Lifter



Single Rail Clamp



Wooden Log Grab



Stone Grab

Custom built tongs designed and manufactured as per customer's requirement.

Number of Units Manufactured: 200+ | Lifting Capacity: 5 MT - 125 MT | SWL - 1.25 | FoS: 3



# SPECIAL LIFTING EQUIPMENT



1200°C 10MT Ring Grab



1200°C 10MT Ring Grab



5MT Wire Rod Coil C-Hook



40MT Roll with Chocks Handling Beam

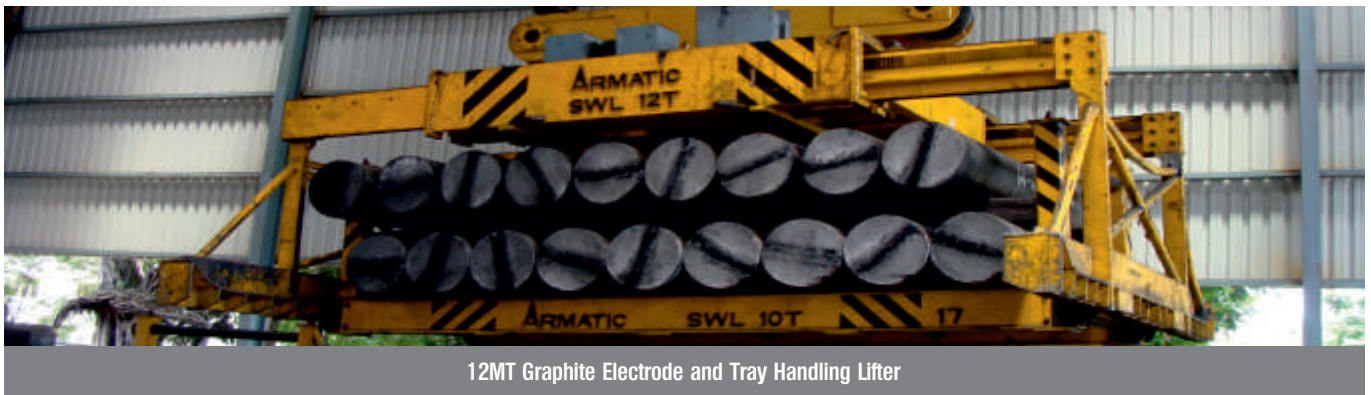

12MT Graphite Electrode and Tray Handling Lifter

Custom built tongs & beam handling equipment designed and manufactured as per customer's requirement.

Number of Units Manufactured: 30+ | Lifting Capacity: 5 MT - 50 MT | SWL - 1.25 | FoS: 3



Electro-Hydraulic Cactus Grab for Garbage



Electro-Hydraulic Grab Bucket



Electro-Hydraulic Grab for Steel Scrap



Hydraulic Grab for excavator



Wire Rope Grab Bucket

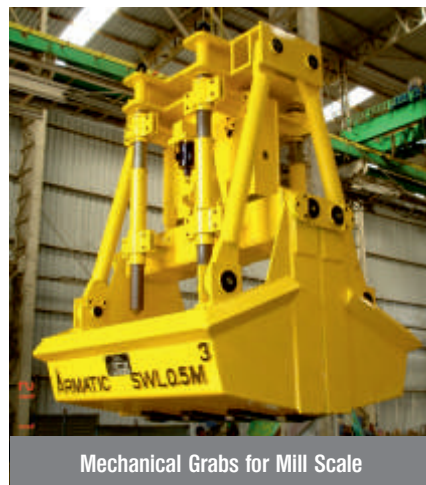

Mechanical Grabs for Mill Scale

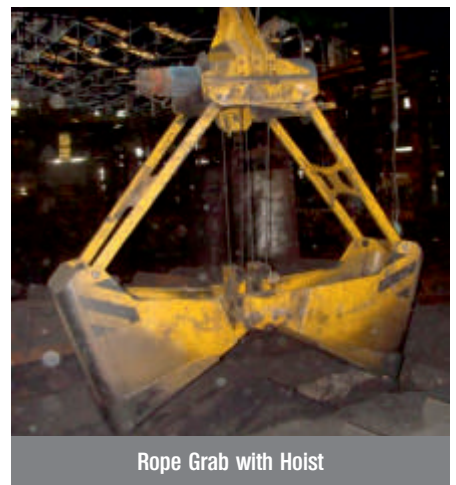

Rope Grab with Hoist

Mechanical / Electro-Mechanical / Hydraulic, wide applications, supplied with cable reeling drum, remote option, continuous duty.

Number of Units Manufactured: 50+ | Lifting Capacity: 0.5M<sup>3</sup> - 15M<sup>3</sup> | SWL - 1.25 | FoS: 3

# SPREADER BEAMS & LADLES



12MT Spreader Beam



185MT Beam for Mill Housing



5MT Adjustable Pallet Lifter



16MT, 12 CBM Charging Bucket



21MT Scrap Bucket



60T Tundish Beam

Spreader beams designed and manufactured as per customer's specification and requirement.

Number of Units Manufactured: 30+ | Lifting Capacity: 5 MT - 185 MT | SWL - 1.25 | FoS: 3



50MT Lifting Beam for Mould Segment



60MT Link Chain - Tundish Beam



120MT Lifting Beam for Mould Segment



32MT Rotating Beam for Crucible Ladle



25MT Launder Lifting Device



75MT Lifting Device

Ladles and Buckets designed and manufactured as per customer's specification and requirement.

Number of Units Manufactured: 35+ | Lifting Capacity: 5 MT - 30 MT | SWL - 1.25 | FoS: 3

# UPENDERS / TILTERS / STACK TURNOVER DEVICE



10MT Sheet Pack Turn-Over Device



40MT Electro-Hydraulic Up-ENDER with Transfer Trolley



25MT Electro-Mechanical Up-ENDER



5MT Sheet Pack Turn-Over Device

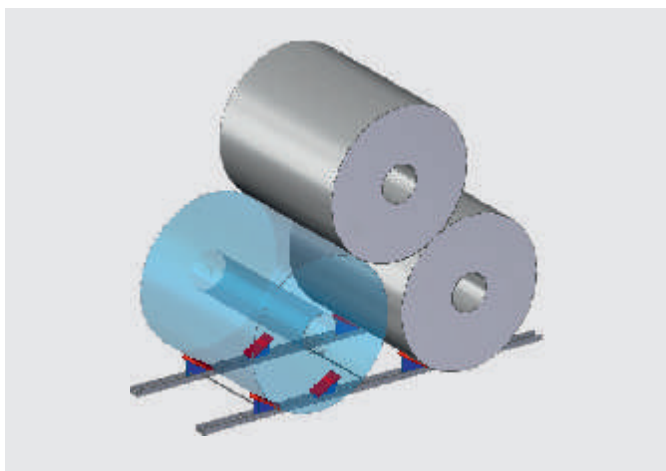

Coil Stacking System



8MT Pallet Turnover Device

Electro-Mechanical & Electro-Hydraulic, tilting devices for various applications.

Number of Units Manufactured: 80+ | Lifting Capacity: 5T - 50T | SWL - 1.25 | FoS: 3

# OUR CLIENT LIST



We work closely with our clients to help them successfully execute their most critical needs in material handling equipment. If you would like to speak with any of our clients regarding their experience with Armatic Engineering Private Limited, please contact us and we will be happy to provide an introduction. Below are few of our customers.



# OUR CUSTOMER BASE



Australia  
Bangladesh  
Columbia  
Dubai  
Egypt  
Ethiopia  
Georgia  
Indonesia  
Italy  
Kenya

Malaysia  
Mexico  
Nepal  
Nigeria  
Oman  
Pakistan  
Rwanda  
Saudi Arabia  
Turkey  
Vietnam



**ARMATIC<sup>®</sup>**  
**ENGINEERING PRIVATE LIMITED**

#8, 27th Cross, Banashankari 2nd Stage, Bangalore-560 070, India  
Tel:+91-80-2671 7078, 2671 1733, Fax: +91-80-2671 3138  
Email: mail@armaticengineering.com, Website : www.armaticengineering.com